

# Smart Lotis 82 ES50

124501XX

Lamp type : RETROFIT LED MAX.50W

Fitting : Gu10

1

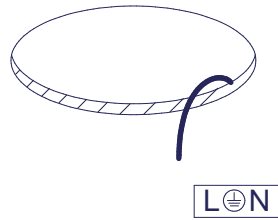

2

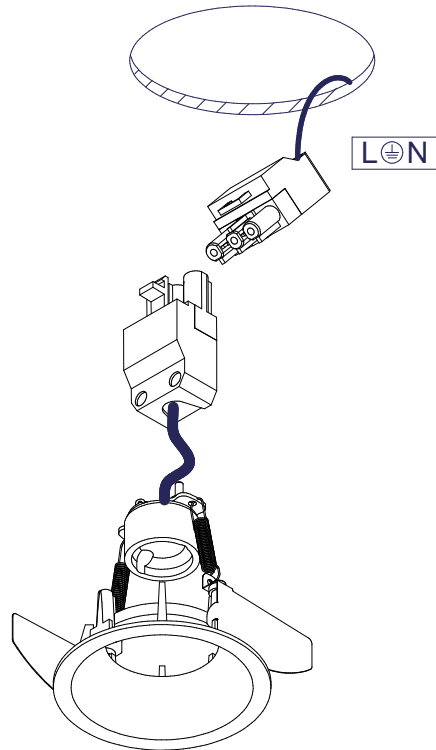

3

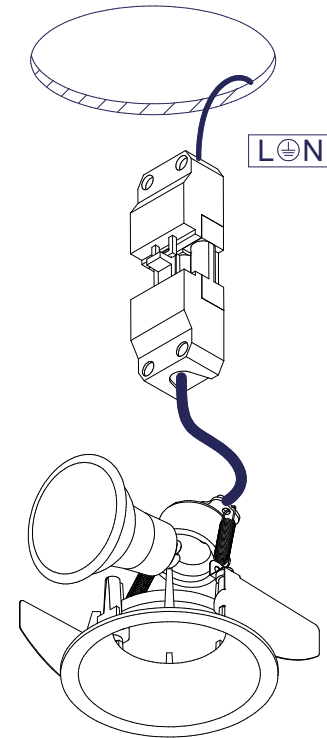

4

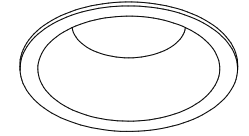

180 mm

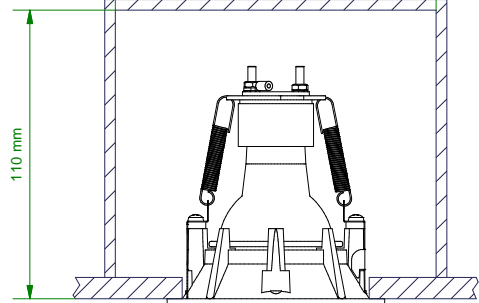

## CAN BE USED WITH

12500009 Smart Mask 1x White Struc  
12500032 Smart Mask 1x Black Struc

12500109 Smart Mask 2x White Struc  
12500132 Smart Mask 2x Black Struc

